

### Overview

The rechargeable batteries are lead-lead dioxide systems. The dilute sulfuric acid electrolyte is absorbed by separators and plates and thus immobilized. Should the battery be accidentally overcharged producing hydrogen and oxygen, special oneway valves allow the gases to escape thus avoiding excessive pressure build-up. Otherwise, the battery is completely sealed and is, therefore, maintenance-free, leak proof and usable in any position.



### Battery Construction

Component	Positive plate	Negative plate	Container	Cover	Safety valve	Terminal	Separator	Electrolyte
Raw material	Lead dioxide	Lead	ABS	ABS	Rubber	Copper	Fiberglass	Sulfuric acid

### General Features

- Positive and negative plates in lead-calcium-tin alloy;
- Stable Quality&High Reliability;
- Sealed Construction;
- Long Service Life;
- Maintenance-Free Operation;
- Low Pressure Venting System;
- Low Self Discharge;
- U.L.Component Recognition;
- Six months shelf life at 20°C;
- Design life 10 years

### Battery Specification

Performance Characteristics	
Nominal Voltage	12V
Number of cell	6
Design Life	10 years
<b>Nominal Capacity 77°F(25°C)</b>	
10 hour rate (7.5A, 10.8V)	75.0Ah
5 hour rate (13.5A, 10.5V)	67.5Ah
1 hour rate (50.2A, 9.6V)	50.2Ah
<b>Internal Resistance</b>	
Fully Charged battery 77°F(25°C)	≤6.6 mOhms
<b>Self-Discharge</b>	
3% of capacity declined per month at 20°C(average)	
<b>Operating Temperature Range</b>	
Discharge	-20~60°C
Charge	-10~60°C
Storage	-20~60°C
Max. Discharge Current 77°F(25°C)	700A(5s)
Short Circuit Current	1800A
<b>Charge Methods: Constant Voltage Charge 77°F(25°C)</b>	
Cycle use	2.40-2.45VPC
Maximum charging current	22.5A
Temperature compensation	-30mV/°C
Standby use	2.20-2.30VPC
Temperature compensation	-20mV/°C

### Dimensions and Weight

Length(mm / inch)	258 / 10.2
Width(mm / inch)	166 / 6.54
Height(mm / inch)	206 / 8.11
Total Height(mm / inch)	215 / 8.46
Approx. Weight(Kg / lbs)	22.5 / 49.6

\* Weight deviation: ± 5%

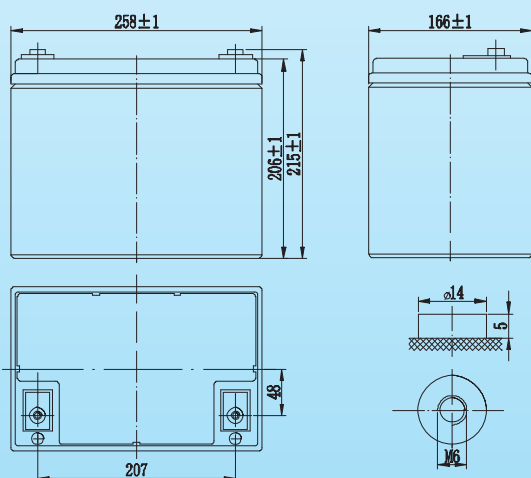

### Discharge Constant Current (Amperes at 77°F25°C)

End Point Volts/Cell	Time							
	10min	15min	30min	45min	1h	3h	5h	10h
1.60V	178	137	81.8	61.7	50.2	21.8	14.3	7.67
1.65V	169	131	78.3	56.4	47.5	21.4	14.1	7.65
1.70V	158	122	77.0	55.0	46.9	21.0	13.9	7.60
1.75V	151	117	73.6	53.7	45.3	20.6	13.5	7.55
1.80V	139	112	73.1	53.3	43.4	19.8	13.3	7.50

### Discharge Constant Power (Watts at 77°F25°C)

End Point Volts/Cell	Time							
	10min	15min	30min	45min	1h	2h	3h	5h
1.60V	314	246	158	120	95.7	54.1	40.2	26.8
1.65V	300	241	153	118	93.6	52.8	39.2	26.6
1.70V	290	237	145	111	89.8	51.6	38.9	26.0
1.75V	274	223	142	111	86.5	50.3	38.3	26.0
1.80V	261	212	141	106	84.2	49.6	38.0	25.8

(Note)The above characteristics data are average values obtained within three charge/discharge cycles not the minimum values.All data shall be changed without notice,Vision reserves the right to explain and update the information contained hereinto.



**VISION GROUP**  
Shenzhen Center Power  
Tech.Co.Ltd.,

# 6FM75-X

## 12V 75Ah(10hr)

